



NJ-iot306

Product use manual of NB-iot (narrow band
Internet of things)municipal electric dual
color temperature lamp controller

Xiamen Nengjia New Energy Technology Co., LTD

www.xmnengjia.com

Updated time: 2022.02.12

I. Product function and features

Nj-iot306B adopts advanced PWM control technology, which is used to control which constant voltage LED lamps can achieve dual color temperature change. It can be added by one key scanning code, eliminating cumbersome installation and adaptation, and speeding up construction and acceptance.

NJ-iot306B street lamp controller built in cable network, double lamp real-time online rate is higher than similar products on the market, according to the WEB page or mobile APP instruction can realize area, street, interval, and side (single, double) scene control, and the main lights, auxiliary lights, main auxiliary, main channel dimming, auxiliary dimming mode control, in order to reduce equipment costs, achieve smooth upgrade. In order to meet the needs of smart city construction, NB-iot independently develops and produces high-tech products with independent intellectual property rights for the information monitoring and management of urban lighting. It has the advantages of reliable operation, flexible and convenient control, and complete functions. A new technology has the characteristics of wide coverage, many connections, high rate, low cost, excellent architecture and so on.

NJ-iot306B street lamp controller collects and reports the input and output current / voltage, active power, apparent power, power, frequency, power factor, temperature, switch lamp status and data communication; main performance characteristics of the controller:

- Using the communication mode of narrow band Internet of things, the terminal

equipment has its own power supply;

- With 0-10V, PWM two dimming interface output;
- At the same time, the dual-circuit light source can be controlled, dimming;
- Mains power planning - two color temperature;
- With remote lights off, lights on, dimming function, timing output;
- Realize current / voltage, active power, dependent power, power, frequency, power factor and other multi-functional detection;
- High-precision data collection scheme, to meet the national electricity meter metering standard;
- With overcurrent / overpressure / underpressure, overload protection, lamp condition and line detection, default lighting and other functions;
- Aluminum shell, internal glue filling, real IP68 waterproof;
- Active reporting of various faults; including lights, drives, line faults, etc.; support various custom network analysis data collection functions;
- Load lightweight system RTOS, support data concurrent fault tolerance function, cell reselection, different-frequency networking, remote upgrade;
- Suitable for switching and dimming of various power LED lights and lamps; support power driver and line input relay multiple off modes;
- Overload protection design based on safety;
- Edge computing, support local policy; network exception / no state local cloud configuration policy;

- Support timing switch, time control mode;
- Modem modulation mode: BPSK;
- Carrier center frequency: 132kHz;
- Communication rate: 5,500 b p s;
- Receiving Sensitivity: -80dB to-60dB;
- Plug and play, support for scanning and convenient installation and registration;
- Industrial grade working temperature: -40°C ~ + 85°C;
- Plug and play, support for scanning and convenient installation and

registration;

- High lightning protection level $\pm 6KV$ (line to line);
- External antenna; simple and convenient and beautiful installation;
- Responding to instructions sent by the center within 3 seconds.

II. Programme

- 1、 Mains power planning - two color temperature

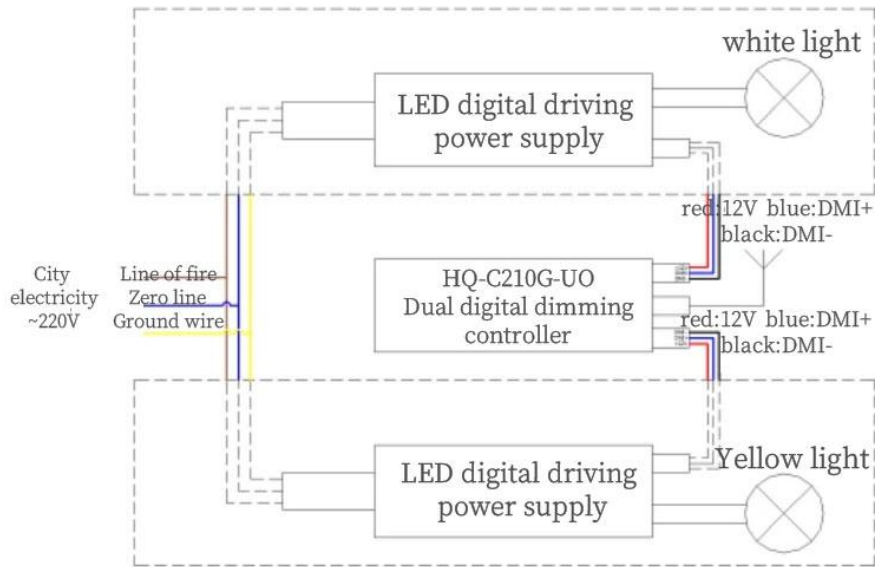

(1) Background white light saves power; Strong yellow light penetration, suitable for rainy weather or high haze scenes.

(2) The dual color temperature street lamp has built-in white light beads and yellow light beads, which can change the color temperature by changing the brightness ratio of white light and yellow light.

(3) The two-color street lamp can not only adjust the color temperature of the street lamp, but also adjust the brightness.

2、programme:

(1) Scheme 1: the color temperature is adjusted by the controller

(2) Scheme 2: the color temperature is adjusted by the software

III. System function implementation

Dual-channel light source module, which can be synchronized and independently controlled;

Automatic status detection, abnormal real-time automatic alarm;

Management control: for different permission users, different display contents (visitors, operator, administrator, super administrator); view, add, edit and delete policies according to the corresponding authority;

Light control function: the system can set different brightness values for each centralized controller, and automatically switch the lights according to the field environment;

GIS map: 3 D, panoramic, plane map, real-time display of the working status of the lamp;

Alarm: accidental lighting, accidental light out, lamp failure, overcurrent, overvoltage, control cabinet phase deficiency, power failure, cable circuit break, power failure, etc., can realize alarm tracking, positioning, backtracking and statistical functions;

Monitoring function: with the remaining battery power of the centralized controller, the internal temperature of the RTU, the circuit switch status, a single street lamp electric parameter (voltage, current, power, power factor);

Remote control function: with real-time switch light, control strategy setting, loop switch, single light switch, single light group switch and other intelligent control functions;

Dimming function: with single light dimming, single light group dimming, single light

10 stage dimming function;

Dual color temperature lamp control: the system can realize accurate to dual color temperature lamp management function, including control, state monitoring, fault alarm, energy saving control;

Independent operation: the equipment can operate automatically according to the original set mode after leaving the control;

Power off operation: the terminal is equipped with uninterruptible power supply, with power off operation function;

Energy consumption report: support lamps energy consumption report generation function, by year / month / day statistical report, list all control cabinet power consumption, lighting rate, power consumption detail this month, energy saving rate, etc., and can query and print according to the requirements of the operator, provide users with energy consumption structure and energy consumption cost analysis, and evaluate the energy saving effect and correlation;

Remote upgrade: The centralized controller supports the remote automatic upgrade;

Time function: system automatic, manual calibration;

Policy management: can realize single control, group control, group control and weekly strategy, monthly strategy, annual strategy, holidays and special control strategy;

Time time statistics function: with the light time statistics, fault time statistics, power accumulated remote reading function;

Asset management: the system can register, increase, reduce, change, query, summarize, report, etc. according to the equipment type; add, edit and delete the lamp type; query, edit

and delete the regional information; view, edit and delete the maintenance unit;

Data storage: with the functions of historical electric parameter record, historical data storage query, single light and loop parameter timing saving, daily power time (lighting time), lighting rate, historical alarm and other storage functions, convenient for user query and statistics;

Each single lamp, branch road can be freely grouped, and the selected group is highlighted;

Stage setting: the system can set the street lamp switch and brightness in the stage, and can set up to 10 different time periods for automatic operation;

Motion induction: the system can easily attach the brightness or motion sensing equipment (infrared, radar, camera, etc.), according to the real-time collected environmental information automatically dimming setting;

IV. Technical parameter

open circuit losses	<1.5W
service voltage	AC: 96~264V
communication mode	NB-iot

Carrier operator	Full netcom
working temperature	-35° C ~ 65° C
levels of protection	IP67
size (mm)	98mmx84mm
Antenna type	outlay

Output one

Maximum load current	4A
power	≤400W
The dimming mode	0-10V/PWM

Output two

Maximum load current	4A
power	≤400W
The dimming mode	0-10V/PWM

IV.Appearance size

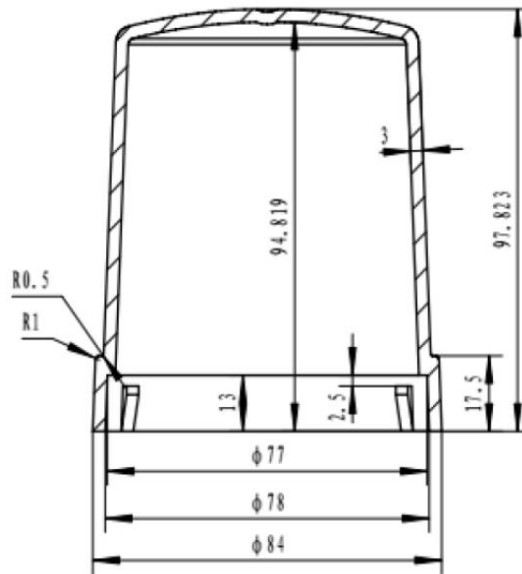

V. Technical parameter

open circuit losses	<1.5W
service voltage	AC: 96~264V
working temperature	-40° C ~ 85° C
levels of protection	IP67

size (mm)	98mmx84mm
communication mode	Nb-iot
Maximum load current	4A
power	≤400W
The dimming mode	0-10V/PWM

VI. Installation instructions

! For safety, you must operate in case of power failure.

A) NB-iot lamp controller (connected according to the positive and negative electrode on the panel)

1. Input terminal: 220V access
2. Output: Connect the input of drive power (dimming power)(Input)
3. Signal end: adjust the light of the drive power supply (dimming power supply)

b) Drive power (dimming power)

1. Input (Input): connect the output of the lamp controller
2. Output end (Output): connecting load (light board)
3. Light adjustment: connect the signal end of the lamp controller

VII. Mode of connection

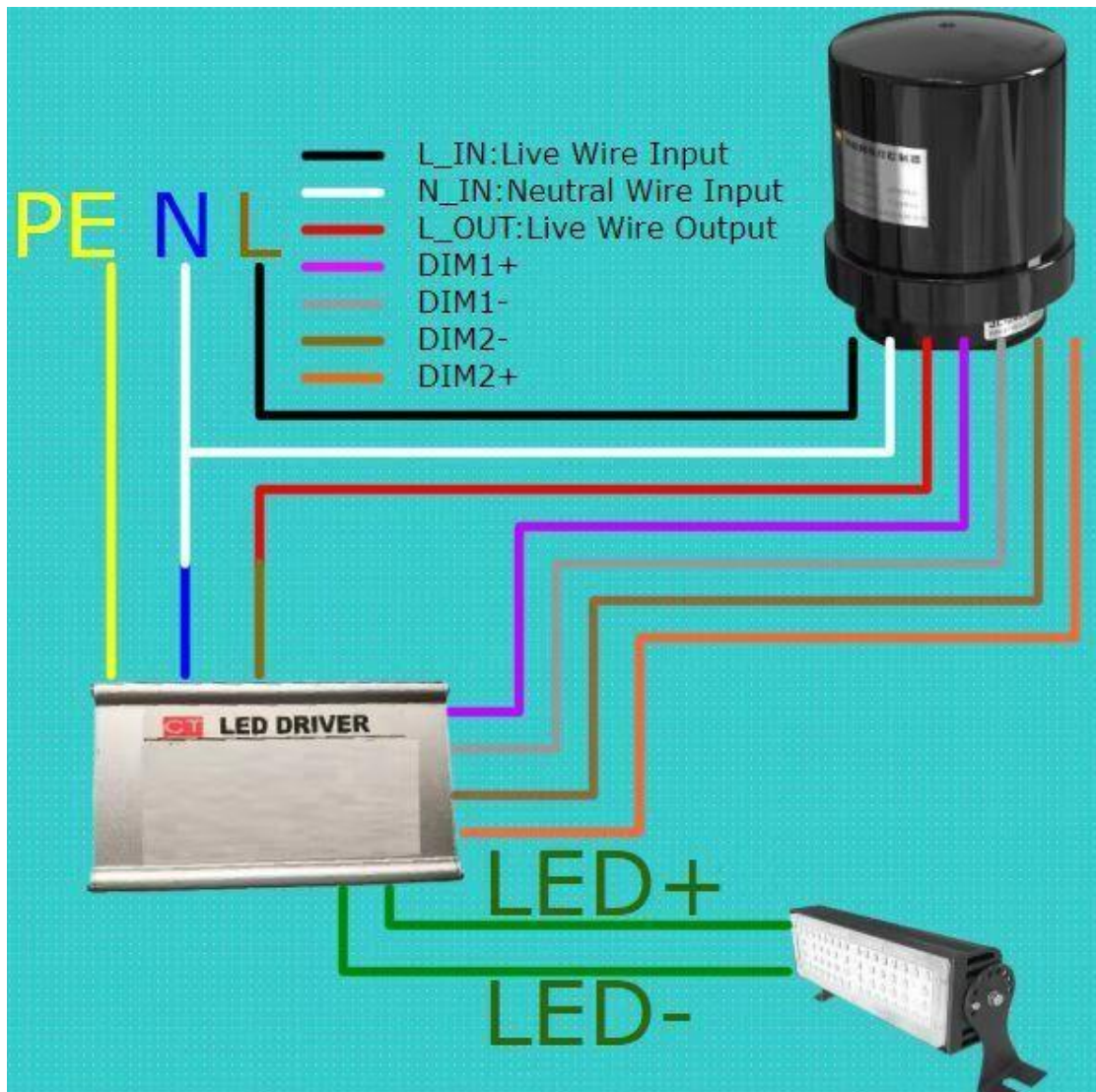

VIII. Technical support