



NJ-iot301

Product use manual of Municipal electric single-lamp controller

Xiamen Nengjia New Energy Technology Co., LTD

www.xmnengjia.com

Updated time: 20210816

I, the product features

The NJ-IoT-302-street light controller is built on a cellular network, consumes only about 180KHz of the frequency band, and is deployed directly in the UMTS network to reduce deployment costs and achieve smooth upgrades. NB-IoT is a new type of technology in the field of IoT, which supports the cellular data connection of low-power devices in the WAN with the characteristics of wide coverage, many connections, low rate, low cost, low power consumption, and excellent architecture.

NJ-IoT-302-way lamp controller to achieve wireless communication, input and output current/voltage, active power, apparent power, power, frequency, power factor, temperature, switch lamp status and data acquisition and reporting; The main performance characteristics of the controller:

- NB-IOT wireless communication mode;
- At the same time, it has 0-10V, PWM dimming output;
- External antenna, transmit power $23\pm 2\text{dBm}$, acceptance sensitivity $-129\pm 1\text{dBm}$, through Huawei compatible Certification;
- The one-time network connection success rate is 99 More than 9%;
- Realize multi-functional detection of current/voltage, active power, apparent power, power, frequency, power factor, etc.;
- High-precision data acquisition scheme to meet the national meter measurement standards;
- 1 channel 0% ~ 100% arbitrary proportion of 1-10V / PWM stepless dimming output function;
- With overcurrent/overvoltage/undervoltage, overload protection, lamp condition and line detection, default lighting and other functions;
- Active reporting of various faults; Including lights, drives, line failures, etc.;
- Support various custom network analysis data collection functions;
- Load the lightweight system RTOS, support data concurrency fault tolerance function, cell reselection, cross-frequency networking, remote upgrade...
- Suitable for all kinds of power LED lamps, lamps and lanterns switch and dimming use; Support multiple off modes of power driver and line input relay;

- Safety-based overload protection design;
- Edge computing, support local policies; Network exception/networkless state automatically executes cloud configuration policies locally;
- Support timer switch, time control mode;
- Frequency band: B5/B8/B3;
- Plug and play, support scanning convenient installation registration;
- Industrial working temperature: -40 °C ~ +85 °C;
- IP66 waterproof rating;
- High lightning protection rating±6KV (line-to-wire);
- External antenna; Simple and convenient installation;
- Response to instructions sent by the center within 3 seconds;

www.xmnengjia.com

II, the appearance and size

Lph D = 100mm * 68mm * 40 mm

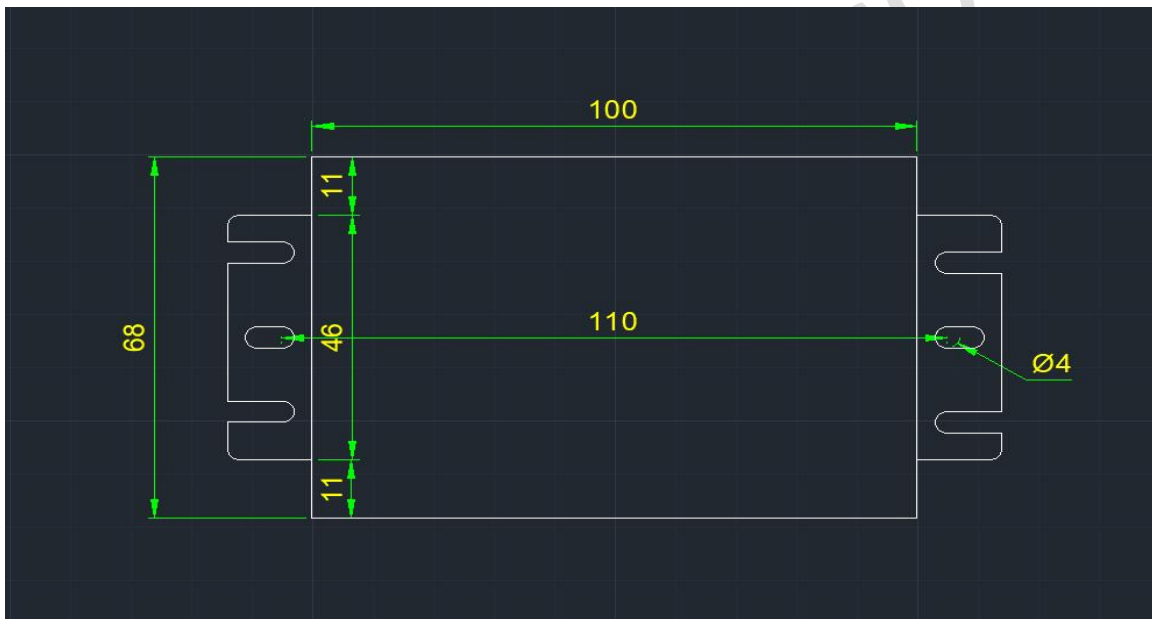



III, technical parameters

Communication method	NB-iot
Supply voltage	AC : 96~264V
No-load power consumption	<1.5W
Operators:	Move by default
Operating temperature	-35°C ~ 65°C
Antenna type	External
Protection class	IP67
Dimensions(mm)	72mmx66mmx21mm

Output one

Maximum load current	4A
power	$\leq 400W$
Dimming mode	0-10V/PWM

Output two

Maximum load current	4A
power	$\leq 400W$
Dimming mode	0-10V/PWM

IV, installation instructions

For safety, it is important to operate in the event of a power outage.

*The antenna should avoid direct contact with metal (including items with shielding function), and should not be placed in a completely enclosed iron container. In addition, the installation should be fixed and reliable, and avoid scratches and insulation damage of the line.

a) Connect the drive power supply

The power supply needs to support 0-10V dimming or PWM dimming driver. The output of the single-lamp controller is connected to the input of the drive power supply. The dimming of the single-lamp controller is connected to the

dimming of the driving power supply. Output 1 should correspond to a power supply with dimming 1, and output 2 should be wired in the same way as output 1.

b) Connect the load

The output of the driving power supply is connected to the light source, and the output of the power supply is direct current.

c) Access to mains power

Ensure that steps A and B are completed, and the input of the single lamp controller is connected to the mains. The luminaires turn on the lights by default

* In addition, the installation should be fixed and secure, and avoid scratches and insulation damage of the line

V, the wiring mode

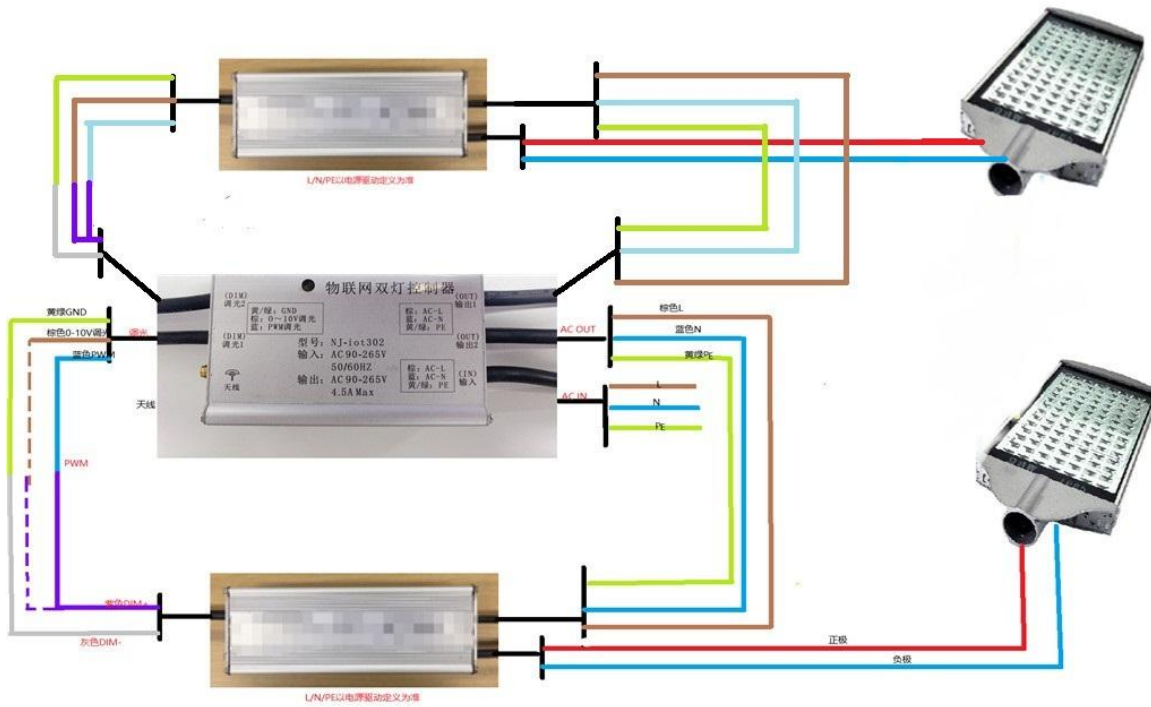

VI, Technical support



能加新能源
NENG JIA XIN NENG YUAN



www.xmnengjia.com

www.xmnengjia.com